

Igo T 139

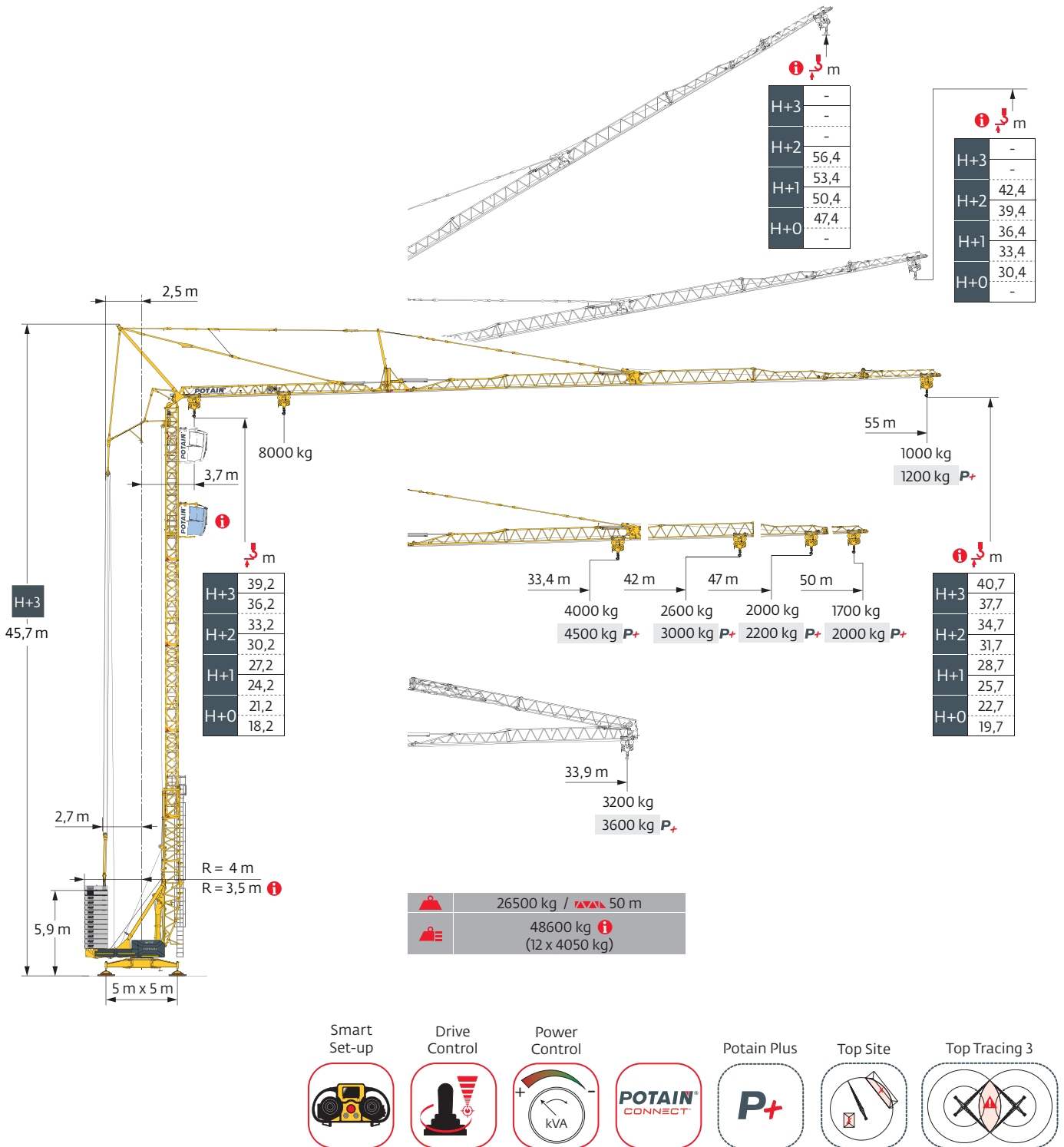

Courbes de charges / Lastkurven / Load curves / Curvas de cargas / Curve di carico
 Curvas de carga / Кривые нагрузок

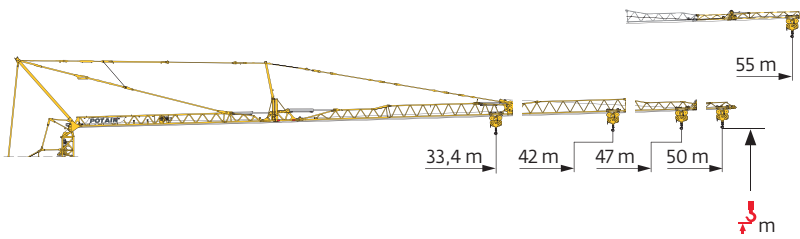

m		33,4	42	47	50	55	
m	H+3	40	40,2	40,4	40,5	40,7	4
		37	37,2	37,4	37,5	37,7	3
	H+2	34	34,2	34,4	34,5	34,7	
		31	31,2	31,4	31,5	31,7	2
	H+1	28	28,2	28,4	28,5	28,7	
	25	25,2	25,4	25,5	25,7		
	22	22,2	22,4	22,5	22,7		
	19	19,2	19,4	19,5	19,7	1	

m	8000 kg	m																							
		10	14	18	20	22	24	26	28	30	32	33,4	34	36	38	40	42	44	47	48	50	52	54	55	m
55	3,7 → 10	8000	5500	4200	3700	3300	3000	2700	2500	2300	2100	-	1950	1800	1700	1600	1450	1400	1250	1200	1150	1100	1050	1000	kg
	3,7 → 10	8000	5800	4500	4000	3600	3300	3000	2800	2550	2400	-	2250	2100	1950	1850	1700	1600	1500	1450	1350	1300	1250	1200	kg P+
50	3,7 → 13	8000	7400	5600	5000	4500	4100	3800	3400	3200	2950	-	2750	2550	2400	2250	2100	2000	1850	1800	1700	kg			
	3,7 → 13	8000	7500	5900	5400	4900	4500	4100	3800	3600	3300	-	3100	2900	2750	2600	2450	2350	2150	2100	2000	kg P+			
47	3,7 → 14	8000	8000	6100	5400	4900	4400	4100	3700	3400	3200	-	2950	2750	2600	2450	2300	2150	2000	kg					
	3,7 → 14	8000	8000	6300	5600	5100	4700	4300	4000	3700	3400	-	3200	3000	2800	2650	2500	2400	2200	kg P+					
42	3,7 → 15	8000	8000	6600	5900	5400	4900	4500	4100	3800	3600	-	3300	3100	2900	2750	2600	kg							
	3,7 → 15	8000	8000	6800	6200	5700	5300	4900	4500	4200	4000	-	3700	3500	3300	3200	3000	kg P+							
33,4	3,7 → 15,5	8000	8000	7100	6500	5900	5500	5100	4700	4400	4200	4000	kg												
	3,7 → 15,5	8000	8000	7200	6700	6300	5900	5500	5200	4900	4700	4500	kg P+												
55	3,7 → 9	7200	5200	4000	3500	3200	2900	2650	2400	2250	2050	-	1900	1800	1650	1550	1450	1350	1250	1200	1150	1100	1050	1000	kg
	3,7 → 9	7300	5400	4300	3900	3500	3200	2950	2700	2500	2350	-	2200	2050	1900	1800	1700	1600	1500	1450	1350	1300	1250	1200	kg P+
50	3,7 → 10,5	8000	6200	4900	4400	4000	3700	3400	3100	2900	2700	-	2550	2350	2250	2100	2000	1850	1750	1700	1600	kg			
	3,7 → 10,5	8000	6400	5200	4800	4400	4100	3800	3500	3300	3100	-	2900	2750	2550	2450	2300	2200	2050	2000	1900	kg P+			
47	3,7 → 11,9	8000	6900	5400	4900	4400	4000	3700	3400	3200	2950	-	2750	2600	2450	2300	2200	2050	1900	kg					
	3,7 → 11,9	8000	7000	5700	5200	4800	4400	4100	3800	3500	3300	-	3100	2950	2800	2650	2500	2350	2200	kg P+					
42	3,7 → 13,5	8000	7700	6100	5500	5000	4600	4200	3900	3600	3400	-	3200	3000	2800	2650	2500	kg							
	3,7 → 13,5	8000	7800	6400	5800	5400	5000	4600	4300	4100	3800	-	3600	3400	3200	3100	2900	kg P+							
33,4	3,7 → 15,5	8000	8000	7100	6500	5900	5500	5100	4700	4400	4200	4000	kg												
	3,7 → 15,5	8000	8000	7200	6700	6300	5900	5500	5200	4900	4700	4500	kg P+												



m		42	47	50	55	
m	H+3	40				4
		37				3
	H+2	34				
		31				2
	H+1	28				
	25					
	22					
	19				1	

m	8000 kg	m											
		10	14	18	20	22	24	26	28	30	32	33,9	m
55 - 50 - 47 - 42	3,7 → 14	8000	8000	6200	5600	5100	4700	4300	3900	3700	3400	3200	kg
	3,7 → 14	8000	8000	6500	5900	5400	5000	4700	4300	4100	3800	3600	kg P+
55 - 50 - 47 - 42	3,7 → 12,5	8000	7300	5800	5300	4800	4400	4100	3800	3500	3300	3100	kg
	3,7 → 12,5	8000	7400	6100	5600	5200	4800	4500	4200	3900	3700	3500	kg P+

Flèche relevée 10° / Ausleger 10° angehoben / Jib raised to 10° / Flecha levantada a 10° / Braccio impennato di 10°
 Lança elevada a 10° / Стрела, поднятая на 10°

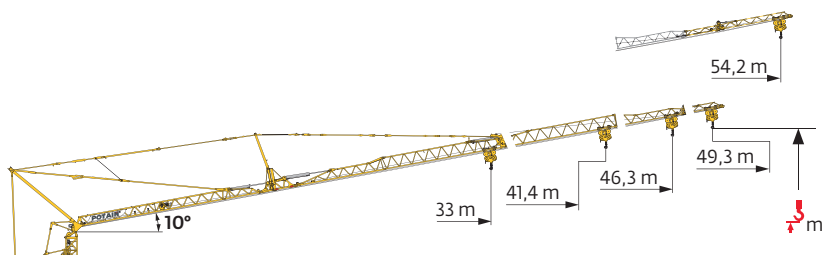

m		33,4	42	47	50	55
m	H+3	-	-	-	-	-
	H+2	38,4	39,9	40,9	41,4	42,4
	H+1	32,4	33,9	34,9	35,4	36,4
	H+0	29,4	30,9	31,9	32,4	33,4
		-	-	-	-	-

3
2
1

m		m																				
55	3,7 → 40	1300	1300	1300	1300	1300	1300	1300	1300	-	1200	1150	1050	-	980	-	920	860	810	800	kg	
50	3,7 → 49,3	1300	1300	1300	1300	1300	1300	1300	1300	1300	1300	1300	1300	1300	1300	1300	kg					
47	3,7 → 46,3	1300	1300	1300	1300	1300	1300	1300	1300	1300	1300	1300	1300	1300	kg							
42	3,7 → 41,4	1300	1300	1300	1300	1300	1300	1300	1300	kg												
33,4	3,7 → 33	1300	1300	1300	kg																	

1
2



m		42	47	50	55
m	H+3	-	-	-	-
	H+2	38,5	-	-	-
	H+1	35,5	-	-	-
	H+0	29,5	-	-	-
		26,5	-	-	-

3
2
1

m		m				
55 - 50 - 47 - 42	3,7 → 33,5	1300	1300	1300	1300	kg

1
2

Flèche relevée 30° / Ausleger 30° angehoben / Jib raised to 30° / Flecha levantada a 30° / Braccio impennato di 30°
 Lança elevada a 30° / Стрела, поднятая на 30°

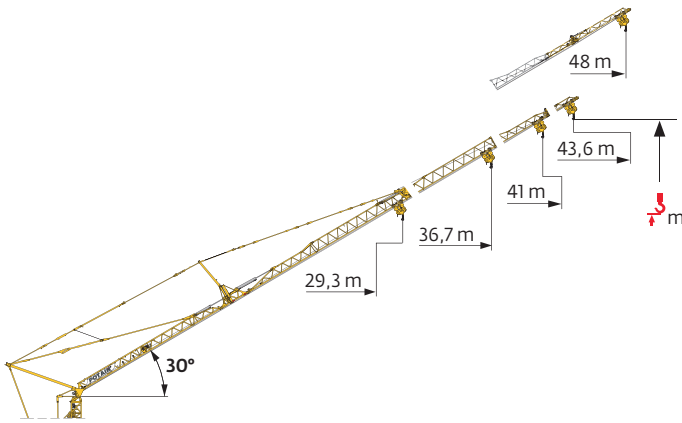

▲▲▲ m		33,4	42	47	50	55
m	H+3	-	-	-	-	-
	H+2	-	55,7	58,3	-	-
	H+1	45,4	49,7	52,3	53,8	56,4
	H+0	39,4	43,7	46,3	47,8	50,4
		-	-	-	-	-

3
2
1

	▲▲▲ m	4000 kg	▲▲▲▲▲																					
			16	18	20	22	24	26	28	29,3	30	32	34	36	36,7	38	40	41	42	43,6	44	46	48	m
1	55	3,7 → 16	4000	3500	3100	2800	2500	2300	2100	-	1900	1750	1600	1500	-	1400	1300	1250	1200	-	1150	1050	1000	kg
	50	3,7 → 21	4000	4000	4000	3800	3500	3200	2900	-	2700	2500	2300	2150	-	2000	1900	1850	1800	1700	kg			
	47	3,7 → 22	4000	4000	4000	4000	3700	3400	3100	-	2850	2650	2500	2350	-	2200	2050	2000	kg					
	42	3,7 → 25	4000	4000	4000	4000	4000	3800	3500	-	3300	3000	2850	2650	2600	kg								
	33,4	3,7 → 29,3	4000	4000	4000	4000	4000	4000	4000	4000	4000	4000	4000	kg										
2	55	3,7 → 16	4000	3500	3100	2800	2500	2300	2100	-	1900	1750	1600	1500	-	1400	1300	1250	1200	-	1150	1050	1000	kg
	50	3,7 → 20,5	4000	4000	4000	3700	3300	3000	2800	-	2550	2350	2200	2050	-	1900	1800	1750	1700	1600	kg			
	47	3,7 → 21,5	4000	4000	4000	3900	3500	3200	3000	-	2750	2550	2400	2250	-	2100	1950	1900	kg					
	42	3,7 → 24	4000	4000	4000	4000	4000	3700	3400	-	3100	2900	2750	2550	2500	kg								
	33,4	3,7 → 29,3	4000	4000	4000	4000	4000	4000	4000	4000	4000	4000	4000	kg										

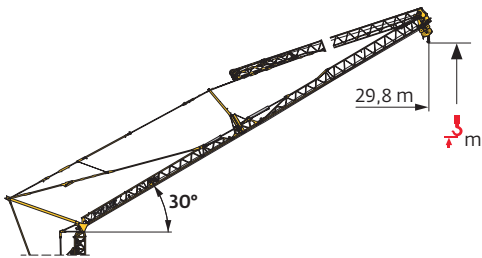

▲▲▲ m		42	47	50	55
m	H+3	-	-	-	-
	H+2	-	-	-	-
	H+1	-	45,7	42,7	-
	H+0	-	39,7	36,7	-
		-	-	-	-



2
1

	▲▲▲ m	4000 kg	▲▲▲▲▲						
			20	22	24	26	28	29,8	m
1	55 - 50 - 47 - 42	3,7 → 24	4000	4000	4000	3700	3400	3200	kg
2	55 - 50 - 47 - 42	3,7 → 23	4000	4000	3800	3600	3300	3100	kg

Mécanismes / Triebwerke / Mechanisms / Mecanismos / Meccanismi
 Mecanismos / Механизмы

400 V - 50 Hz 480 V - 60 Hz		UU (100%)							UU (100% 10°)			ch - PS hp	kW
↑	25 HPL™ 20	m/min	1,5	11,5	15	22,5	35	51	1,5	41,5	51	25	18
		kg	8000	8000	6000	4000	2000	500	1300	1300	500		
↔	5 DVF 5 Optima	m/min	14,7	39	55	70			14,7	39	55	5	4
		kg	8000	8000	2000	200			1300	1300	200		
⊙	HPS 162	tr/min U/min rpm	0 → 0,8									2 x 7,5	2 x 5,5

400 V - 50 Hz 480 V - 60 Hz		UU (100% 30°)					ch - PS hp	kW	
↑	25 HPL™ 20	m/min	3	22,5	29,5	42	61	25	18
		kg	4000	4000	3000	2000	1000		
↔	5 DVF 5 Optima	m/min	14,7	29	29	29	29	5	4
		kg	4000	4000	3000	2000	1000		
⊙	HPS 162	tr/min U/min rpm	0 → 0,8					2 x 7,5	2 x 5,5

IEC 60204-32	kVA
400 V (+10% -10%) 50 Hz / 480 V (+6% -10%) 60 Hz	 32 → 23 kVA  36 → 26 kVA

Montage / Montage / Erection / Montaje / Montaggio
 Montagem / Монтаж

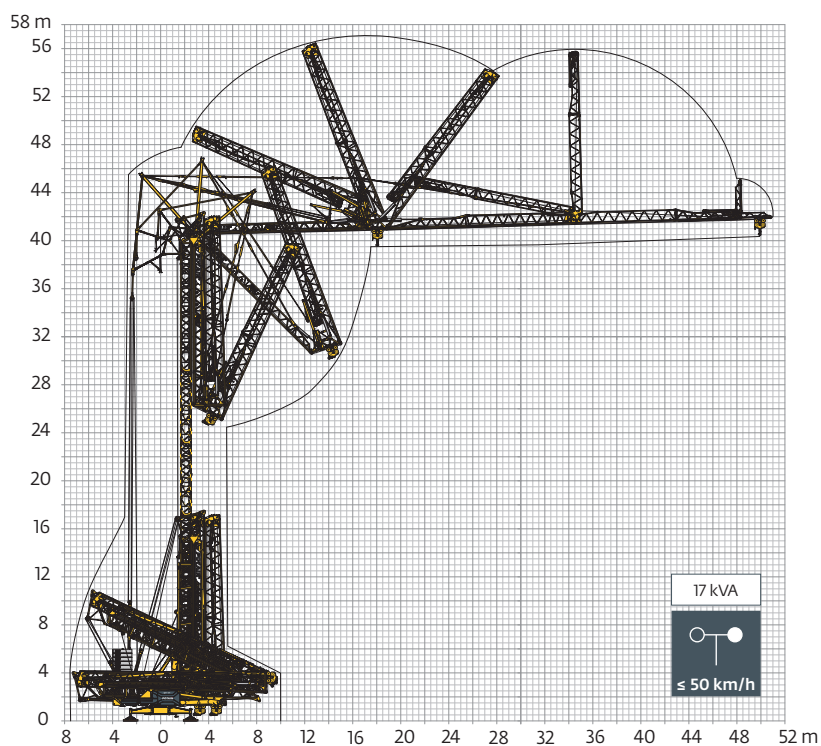

Transport / Transport / Transport / Transporte / Trasporto
 Transporte / Транспортировка

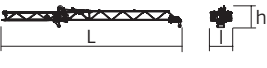
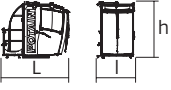
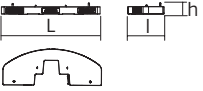
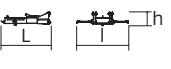
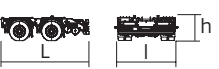
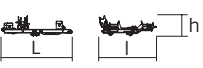

Encombrement et poids / Abmessungen und Gewicht / Dimensions and weight / Dimensiones y peso
 Ingombro e peso dimensões e pesos / габаритные размеры и вес

Description / Beschreibung / Description / Descripción / Descrizione / Descrição / описание	L (m)	l (m)	h (m)	kg (+/- 5%)	
 <p>Mât rallonge / Verlängerungsmast Extension mast / Tramo prolongador Elemento di sopralzo / Tramo prolongador ДОПОЛНИТЕЛЬНАЯ МАЧТА</p>	6	0,91	1	1150	
 <p>Option flèche 55 m / 55 m Ausleger-Option 55 m jib option / Opción Flecha de 55 m 55 m di jib ausiliario / Opção de lança de 55 m стрела 55м, опция</p>	47 m --> 55 m	8,1	1	440	
 <p>Cabine / Kabine Cab / Cabina Cabina / Cabina Кабина</p>	Ultra View	3,1	1,7	2,5	875
 <p>Dalle de lest / Ballastplatte Ballast slab / Bloque de lastre Blocco di zavorra / Bloco de lastro Балластный блок</p>		4,4	1,6	0,51	4050
 <p>Attelage pour sellette / Sattelkupplung Fifth wheel adaptor kit / Enganche de quinta rueda Attacco per selletta / Engate de quinta roda Сцепное устройство</p>	SL122	2,19	2,3	0,6	360
 <p>Train de transport 80 km/h / Transportachse 80 km/h Transport axle 80 km/h / Tren de transporte 80 Km/h Velocità di trasporto 80 km/h Eixo de transporte 80 km/h Прицеп для транспортировки, 80км/ч</p>	J215M	3,72	2,45	1,1	2300
 <p>Kit d'adaptation arrière / Kit für die hintere Transportachse / Rear adaptation kit Kit de adaptación trasero Kit adattamento per assale di trasporto posteriore Kit de adaptação traseiro Задний переходной комплект</p>	Kit 213	2,32	1,87	0,65	425

Transport routier / Straßentransport / Road transport / Transporte por carretera / Trasporto su strada
 Transporte por estrada / Транспортировка

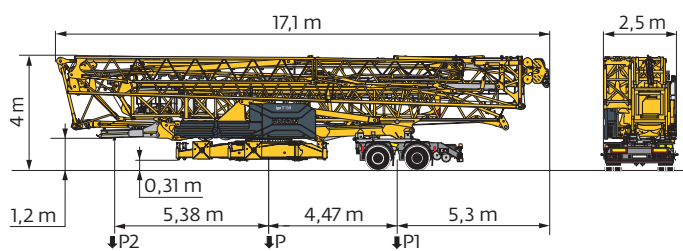

	km/h	P (kg)	P1 (kg)	P2 (kg)
SL122/J215M (EBS)	80	29615	18753	10862

	FR	DE	EN	ES	IT	PT	RU
	Rayon de giration	Schwenk radius	Rear slewing radius	Radio de giro	Raggio di rotazione	Raio de rotação	Задний габарит
	Nous consulter	AufAnfrage	Consult us	Consultarnos	Consultateci	Consultar-nos	Проконсультируйтесь у нас
	Poids à vide, sans lest, sans trains de transport, avec flèche maxi. et hauteur standard.	Gewicht ohne Last, ohne Ballast, ohne Transportachsen, mit max. Auslager und Standardhöhe	Weight without load, without ballast, without transport axles, with max. jib and standard height	Peso en vacío, sin lastre, sin trenes de transporte con flecha y altura estandar	Peso a vuoto, senza zavorra, senza assali di trasporto, con braccio max e altezza standard.	Peso em vazio, sem lastro, sem eixos de transporte com lança máxima e altura standard.	Вес без груза, без балласта, без осей для транспортировки, с максимальным вылетом стрелы и стандартной высотой
	Poids total du lest	Ballast-Gesamtgewicht	Total ballast weight	Peso total del lastre	Peso totale della zavorra	Peso total do lastro	Общий вес балласта
	Fonction Potain Plus : Courbes de charges Plus	Funktion Potain Plus: Plus-Lastkurven	Potain Plus function: Plus load curves	Función Potain Plus: Diagrama de cargas Plus	Funzione Potain Plus: Curve di carico Plus	Função Potain Plus: Diagrama de cargas Plus	Функция контроля мощности Potain Plus: Диаграммы грузоподъемности Plus
	Équipements standards	Standardausrüstungen	Standard equipment	Equipamiento de serie	Equipaggiamento standard	Equipamento de série	Стандартное оборудование
	Équipements optionnels	Sonderausrüstungen	Options	Equipamiento opcional	Equipaggiamento in opzione	Equipamento opcional	Дополнительное оборудование (опция)
	Levage	Heben	Hoisting	Elevación	Sollevamento	Elevação	Подъем
	Distribution	Katzfahren	Trolleying	Distribución	Distribuzione	Distribuição	Перемещение по стреле
	Orientation	Schwenken	Slewing	Orientación	Rotazione	Rotação	Поворот
	Puissance requise	Erforderliche Leistung	Required power	Potencia Necesaria	Potenza richiesta	Potência Necessária	Потребляемая мощность
	Fonction Power Control : vitesses treuils adaptées à la puissance disponible	Funktion Power Control: Geschwindigkeiten der Triebwerke werden an die verfügbare Leistung angepasst	Power Control Function: winch speeds adapted to the available power	Función Power Control: marchas de los cabrestantes adaptadas a la potencia disponible	Funzione Power Control: velocità degli argani adattate alla potenza disponibile	Função Power Control: velocidades de guincho adaptadas à potência disponível	Функция контроля мощности Power Control: регулировка скорости лебедок в зависимости от доступной мощности
	Hauteurs sous crochet données moufle plaquée	Hakenhöhen werden mit plattiertem Haken angegeben	Hook heights given with plated pulley block	Altura bajo gancho con pasteca bloqueada	Altezza sotto gancio con bozzello in contatto con carrello	Altura ao gancho com o cadernal em contacto com o carrinho	высота под крюком дана при условии, что крюковая подвеска соприкасается с кареткой
	Document commercial non contractuel	Unverbindliches Vertriebsdokument	This commercial document is not legally binding	Documento comercial no contractual	Documento commerciale non vincolante	Documento comercial não contratual	Этот коммерческий документ не является юридически обязательным
	Pour toute information technique se référer à la notice correspondante	Für technische Informationen, siehe die entsprechenden Anweisungen	For any technical information, please refer to the corresponding instructions	Para cualquier información técnica, ver la noticia correspondiente	Per tutte le informazioni tecniche fare riferimento al catalogo istruzioni	Para qualquer informação técnica complementar consultar as respectivas instruções	Для получения технической информации, см. соответствующие инструкции

